

ABSTRACT:

In this test report we investigate the two way 2 MHz communications between DIRECTV receivers and SWM switches. Customers have reported error code 771A in some MDU installations resulting in H24 receiver lock-up and grey screens. We replicated the error code and measured the signal levels resulting in the error code.

DIRECTV AIM METER TESTS

A DIRECTV AIM Advanced Installation Meter was used to measure the maximum 2 MHz attenuation allowed for a PASS result in the LF test. A step attenuator was placed between the SWM16 output and the AIM meter. The attenuation was increased to **32 dB** until a **FAIL** reading was obtained. The AIM meter indicated a power level of **-35.9 dBm FAIL**.

LIVE SIGNAL TESTS

SONORA instrumented a SWM16 switch connected to a MSAT-2 splitter feeding (2) MSAT-4 splitters connected to H24, HR24, HR22 and HR20 receivers. The SWM16 signals were amplified with model LA141R amplifiers and the total signal was reduced with step attenuators to effectively attenuate just the 2 MHz signal until error code 771 was detected.

| RECEIVER | 37 dB | 39 dB | 49 dB | 60 dB | 63 dB |
|----------|-------|-------|-------|-------|-------|
| H24 | OK | 771A | 771A | 771A | 771A |
| HR24 | OK | OK | OK | OK | 771A |
| HR22 | OK | OK | 771A | 771A | 771A |
| HR20 | OK | OK | OK | 771 | 771 |

Contents

2 MHz SWiM LF POWER TEST 1.....2

2 MHz RECEIVER THRESHOLD TEST.....3

SWM16 & H24-700 OUTPUT SIGNALS.....4

MSAT-4 TO RECEIVER SIGNALS.....5

What are the contributors to 2 MHz loss?

A typical **HOME installation** allocates (8) tuners per SL5S or SL3S. The SL3S or SL5S output is first split by a MSPLIT-8 having 16 dB loss at 2 MHz. The drop might be 100 feet adding 0.5 dB more 2 MHz loss. The power inserter has 1.5 dB 2 MHz loss.....-16 dB, -0.5 dB, -1.5 dB = **-18 dB**

A typical **MDU installation** allocates (4) tuners per apartment. The SWM output is first split by a MSAT-2 having 4 dB loss at 2 MHz. The drop might be 200 feet adding 1 dB more 2 MHz loss. At the apartment a MSAT-4 would be used with a 2 MHz loss of 11 dB. The SWM channels may be low with this long drop so a LA141R-T would be used before the MSAT-2 adding 2 dB more loss at 2 MHz.....-2 dB, -4 dB, -1 dB, -11 dB = **-18 dB**

CONCLUSION

The DIRECTV AIM meter allows **31 dB** of attenuation at 2 MHz before issuing a FAIL warning. Live signal tests on receivers indicate at least **37 dB** of 2 MHz attenuation is allowed before receivers issue a 771A error code. Typical Home and MDU installations have **18 dB** attenuation at 2 MHz.

2 MHz AIM TEST

TEST Equipment:

- DBS Dishes & LNBS (SLIMLINE & SL5, DTV66E)
- Slope Equalizer (SEQ509)
- LNB power Inserter (5SATPL)
- Step attenuator 10 dB (JFW Industries 75R-050F)
- Step attenuator 1 dB (JFW Industries 75R-089F)
- Installation Meter (AIM)

Analyzer Set Up:

- **Resolution Bandwidth:** 100 kHz
- **Video Bandwidth:** 10 kHz
- **Reference Level Offset:** 6 dB (for 50 to 75 pad)
- **Attenuation:** Adjust to keep peaks (1) division below the reference level

Procedure:

1. Install the distribution equipment per the test diagram and verify the signals using the AIM EIV test.
2. Select TEST / 3. SWiM LF Power Test
3. Set the Step Attenuator to 0 dB attenuation.
4. Measure the SWiM LF power originating from the SWM16.
5. Increase the step attenuator in 10 db steps repeating the 3. SWiM LF Power Test until a FAIL result.
6. Decrease the step attenuator by 10 db, then increase the attenuation in 1 dB steps repeating until a FAIL result.
7. Note the total attenuation and the dBm power reading from the AIM Meter.

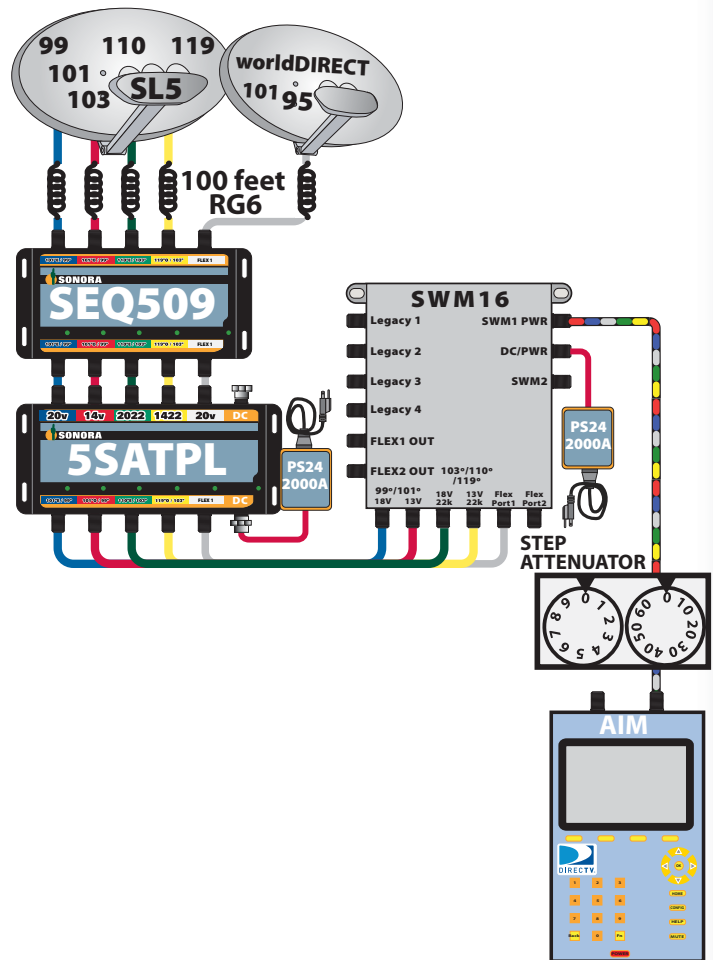

RESULT:

1. An attenuation of **31 dB** resulting in a PASS reading with a measured power level of -34.9 dBm.
2. An attenuation of **32 dB** resulting in a FAIL reading with a measured power level of -35.9 dBm.

TEST Equipment:

- DBS Dishes & LNBs (**SLIMLINE & SL5, DTV66E**)
- Slope Equalizer (**SEQ509**)
- LNB power Inserter (**5SATPL**)
- Step attenuator 10 dB (JFW Industries **75R-050F**)
- Step attenuator 1 dB (JFW Industries **75R-089F**)
- DBS 2-way splitter (**MSAT-2**)
- DBS 4-way splitter (2) (**MSAT-4**)
- DBS Directional Coupler (2) (**HRT116**)
- DIRECTV **BSFR0-01** MRV filter
- Spectrum Analyzer (**HP-E4403B**)
- Installation Meter (**AIM**)
- 50 to 75 ohm matching pads (**HP-0955-1020**)
- Bench-Link data logging software

Analyzer Set Up:

- **Resolution Bandwidth:** 100 kHz
- **Video Bandwidth:** 10 kHz
- **Reference Level Offset:** 6 dB (for 50 to 75 pad)
- **Attenuation:** Adjust to keep peaks (1) division below the reference level

Procedure:

1. Install the distribution equipment per the test diagram with the Step Attenuator set to 9 dB and verify each receiver is locked and displaying a program.
2. Connect the spectrum analyzer to the SWM16 HRT116 tap port. Record the SWM output from 500 to 2000 MHz. Record the SWM output from 500 kHz to 5 MHz.
3. Connect the spectrum analyzer to a MSAT-4 output port. Record the SWM output from 500 to 2000 MHz.
4. Connect the spectrum analyzer to the H24 HRT116 tap port. Record the receiver output from 500 kHz to 5 MHz. **Remove the tap after this test.**
5. Increase the step attenuator in 1 db steps monitoring the receiver output displays until pictures start to freeze and error code 771 or 771A appears.

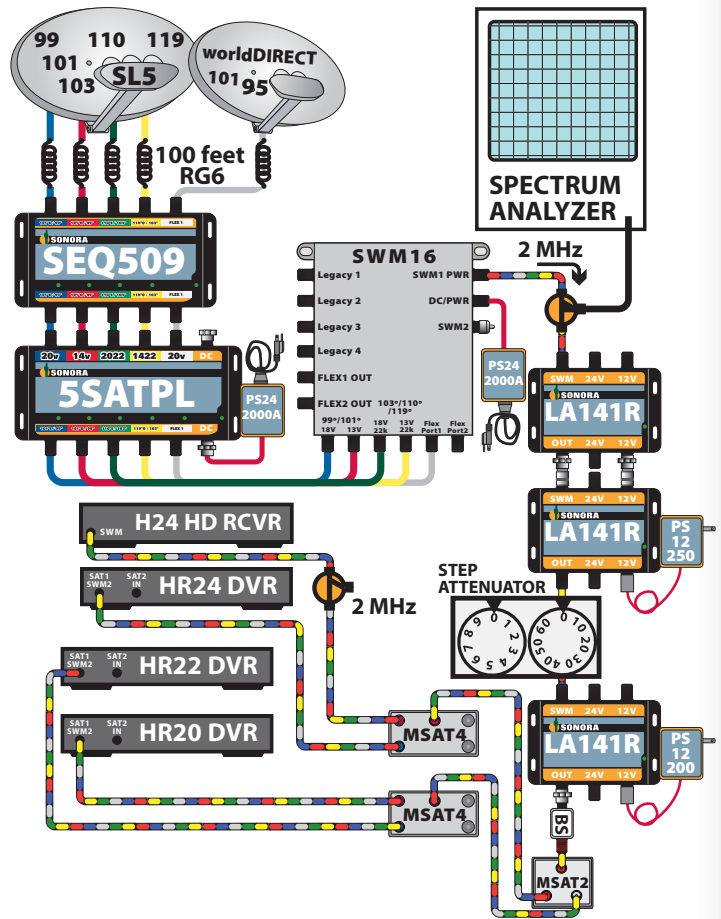

6. The various model receivers may experience the error a different attenuation levels.
7. Note the 2 MHz loss for the system components is as follows: HRT116 = 2.5 dB, LA141R = 2 dB, MSAT-2 = 4 dB, MSAT-4 = 11 dB. Total loss less step attenuator is (2.5+2+2+2+4+11) = 23.5. The HRvT116 tap at the H24 was removed to run the test in step 5. The table below includes the 23.5 dB system loss + attenuator loss.

| RECEIVER | 37 dB | 39 dB | 49 dB | 60 dB | 63 dB |
|----------|-------|-------|-------|-------|-------|
| H24 | OK | 771A | 771A | 771A | 771A |
| HR24 | OK | OK | OK | OK | 771A |
| HR22 | OK | OK | 771A | 771A | 771A |
| HR20 | OK | OK | OK | 771 | 771 |

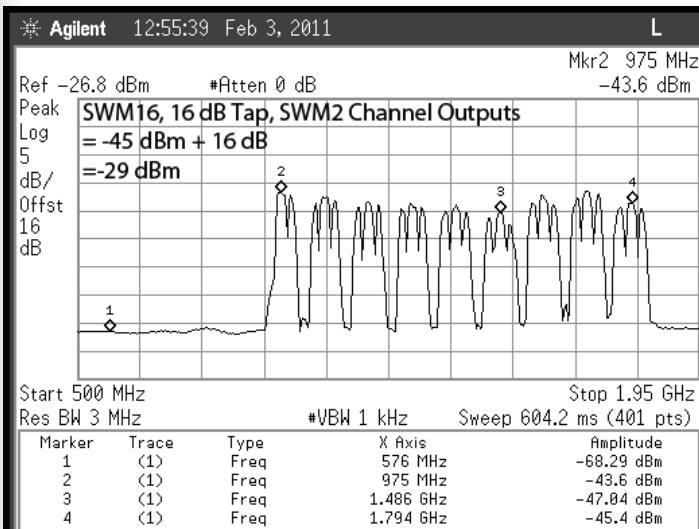

Model HP E4403B analyzer was used to measure the forward and return signals.

The top plot illustrates the (9) forward SWM channels originating from the SWM2 output port. For this measurement The SWM16 has an output level of -29 dBm.

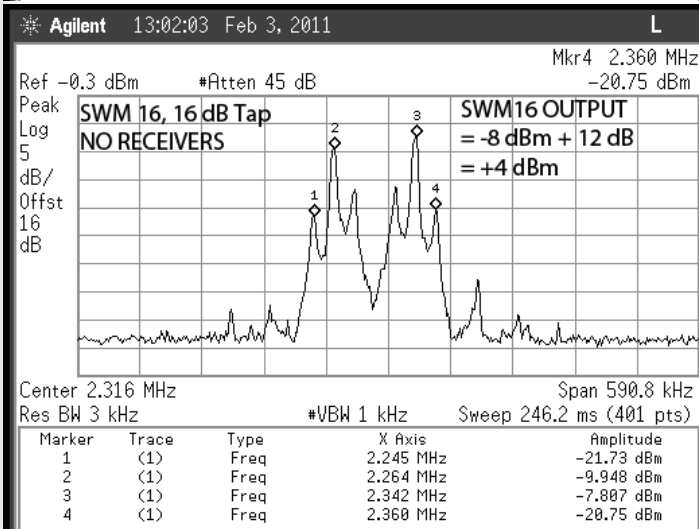

The SW16 generated control signals from 2.25 MHz to 2.36 MHz. ALL receivers were disconnected from the MSAT-4 splitters to prevent their 2 MHz signals from influencing the measurement.

The spectrum analyzer was configured for "Max Hold" to capture the peak levels of the 2 MHz. In real time the signals are jumping up and down indicating a timed signal sequence to receivers.

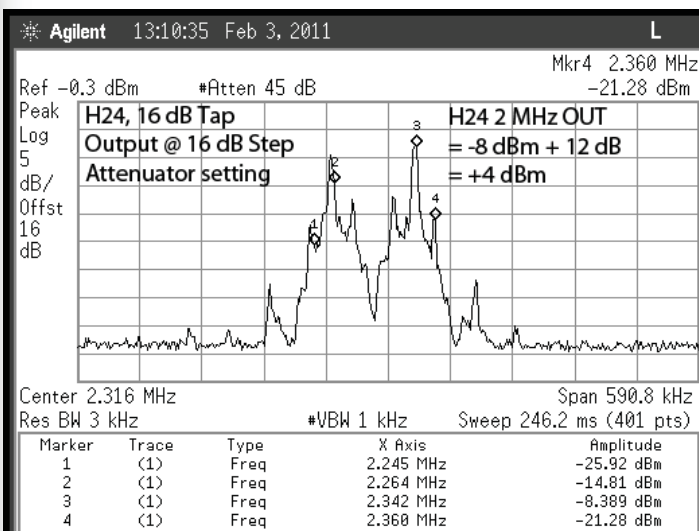

The receivers generate control signals from 2.25 MHz to 2.36 MHz. An in-line 16 dB tap is used to measure the signals without disrupting communication to the SWM16. The tap is directional to allow the tap port to measure the signals from the receiver while rejecting the signals from the SWM16.

The 16 dB tap has a measured 2 MHz tap loss of 12 dB. The calculated H24-700 output is -8 dBm + 12 dB tap loss = +4 dBm.

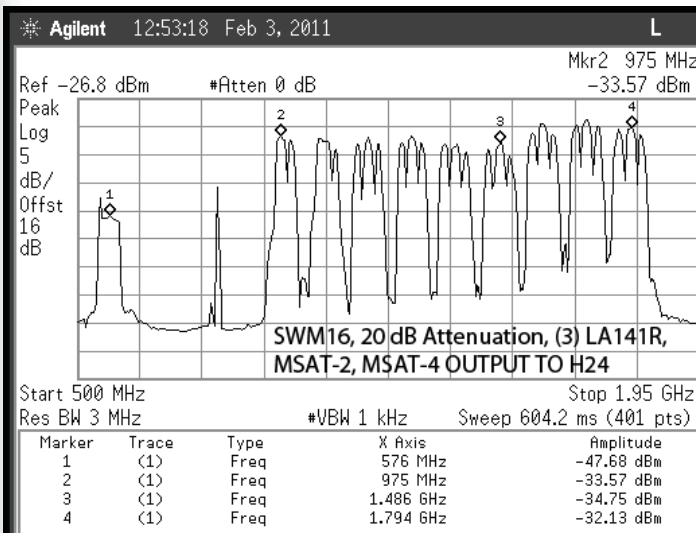

The test configuration was modified removing the HRvT116 tap from the receiver output.

The 2 MHz loss with 0 dB step attenuation was 23.5 dB. (2.5 dB for the HRvT116, 2 dB for each LA141R, 4 dB for the MSAT-2, 11 dB for the MSAT-4)

The plot on the left illustrates the SWM channel output from the MSAT-4 splitter when the step attenuator was set to 20 dB. The SWM level was -32 dBm.

The step attenuation was slowly increased while monitoring the video output of each receiver.

ALL receivers worked with 14 dB of step attenuation (37 dB total)

@ 16 dB of step attenuation, the H24 registered error code 771A (39 dB total)

@ 26 dB of step attenuation, the HR22 registered error code 771A (49 dB total)

@ 37 dB of step attenuation, the HR20 registered error code 771A (60 dB total)

@ 40 dB of step attenuation, the HR24 registered error code 771A (63 dB total)

| RECEIVER | 37 dB | 39 dB | 49 dB | 60 dB | 63 dB |
|----------|-------|-------|-------|-------|-------|
| H24 | OK | 771A | 771A | 771A | 771A |
| HR24 | OK | OK | OK | OK | 771A |
| HR22 | OK | OK | 771A | 771A | 771A |
| HR20 | OK | OK | OK | 771 | 771 |

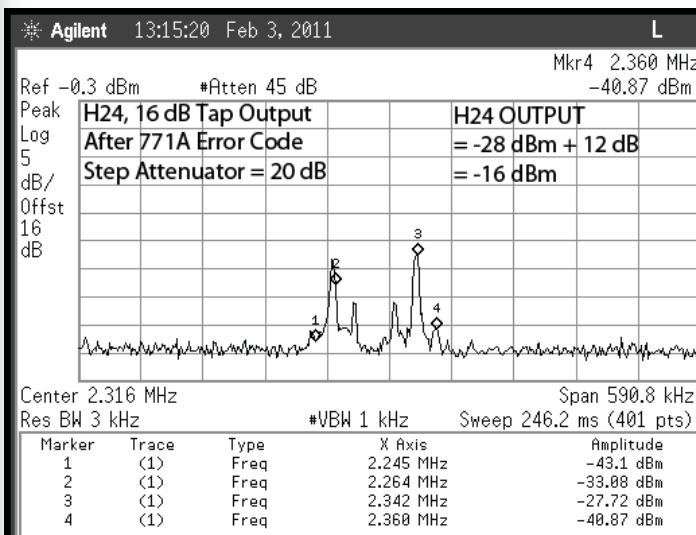

Once the H24 receiver generated error code 771A, it lowered it's 2 MHz output from + 4 dBm to -16 dBm.

Once the 2 MHz attenuation was reduced, the H24 receiver was reset to the full +4 dBm 2 MHz output by disconnecting and reconnecting the drop cable.