

DBS / ATSC AMPLIFIERS

LA141a, 142a, 143a, 144a, 145a

SITUATION

DBS Ka/Ku or ATSC off-air signals are required at multiple locations connected via coax cable. Signal loss must be off-set.

SOLUTION

Models LA141a, LA142a, LA143a, LA144a or LA145a may be placed after a DBS dish or ATSC antenna to extend the signals the equivalent of 150 feet of RG-6 cable.

RELATED CONSIDERATIONS

LA14a series amplifiers have 14 dB gain.

LA28a series amplifiers have 28 dB gain with higher output power.

LAL20a series with automatic gain are preferred in cascade to simplify design and installation.

FEATURES

- ATSC / Ka/Ku bandwidth 175 to 2150 MHz
- High Input Ability -28 dBm
- DC & 22 kHz/DiSeQc passing low insertion
- Indoor / Outdoor case die cast aluminum
- Multiple power options line or external DC

APPLICATION NOTES

Model LA145a amplifiers may be used as part of a DIRECTV® multi-floor apartment distribution system.

Model 5SATPL power supply and polarity locker provides strong DC and control signals to power the SL5 LNB and amplifier.

Model SEQ409 provides signal equalization for maximum signal amplification.

Model SWMBOX-32 hubs at each IDF hold up to (4) SWM8 switches in a 12" x 18" x 9" lock box.

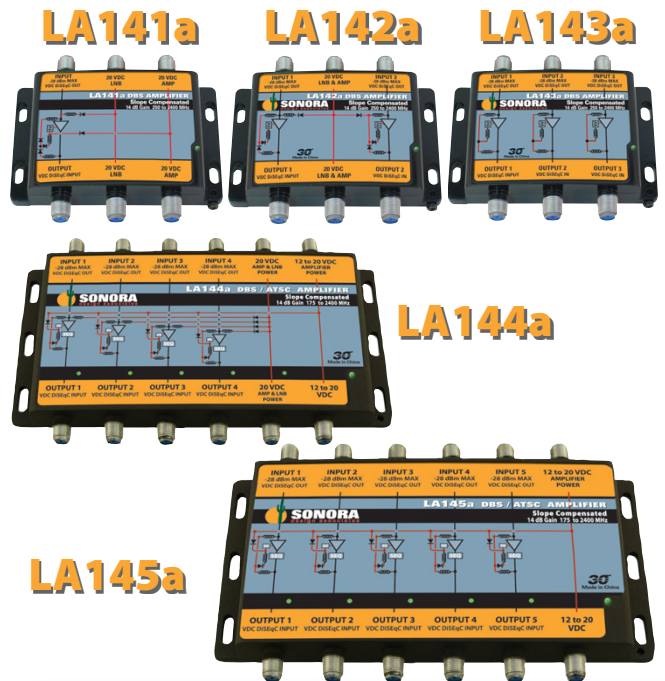

DESCRIPTION

Indoor / Outdoor 175 to 2150 MHz DBS / ATSC line powered amplifiers with 14 dB gain and optional external powering.

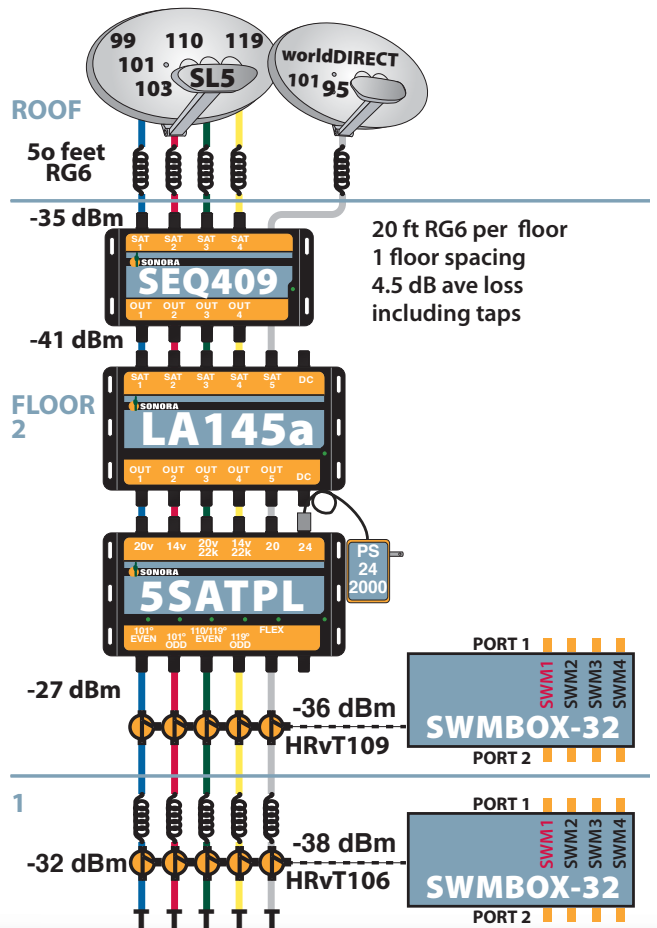

DBS / ATSC AMPLIFIERS

LA141a, 142a, 143a, 144a, 145a

LA141a, LA142a and LA144a & LA145a amplifiers are designed for multiple powering options.

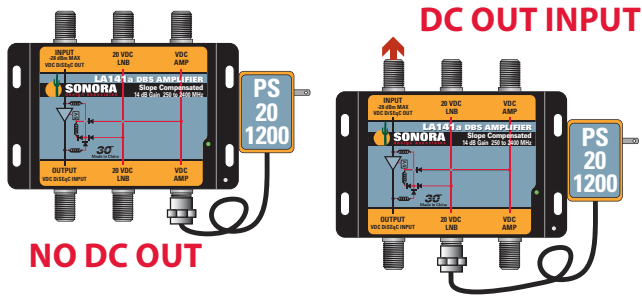

Side Car Powering

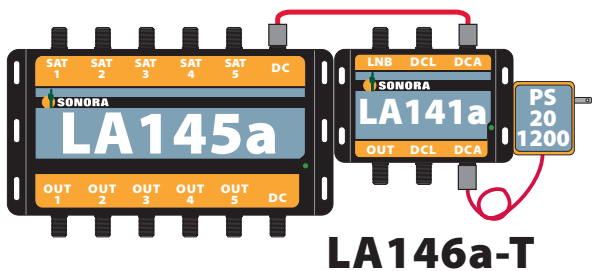

LA146a-T

Amplifiers pass voltage and 22 KHz tones from RF out put to RF input and from RF input to RF output. Each polarity is independently powered.

An external power source can be used to power the amplifiers. Order models LA141a-T, LA142a-T, LA144a-T or LA145a-T to receive an external supply.

Model HRPID1422 provides in-line power for a LA144a amplifier. Model 5SATPL provides in-line power for a LA145a amplifier.

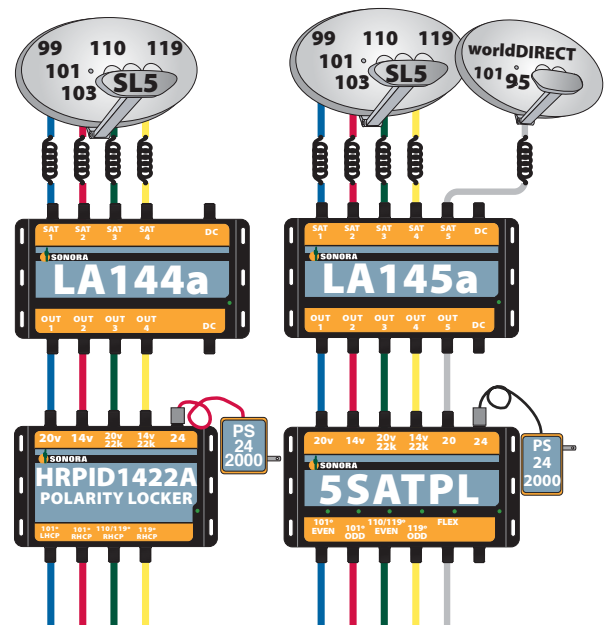

SPECIFICATIONS

Specifications..... Typical QC Limit
Gain

175 MHz	10 dB.....	9 dB
250 MHz	10 dB.....	9 dB
950 MHz	11 dB.....	10 dB
2150 MHz.....	14 dB.....	13 dB
2400 MHz.....	13 dB.....	11 dB

Maximum Input (67 equal transponders) -24 dBm

Maximum Output Power

IM2 with 2 tones @ 1 dBm.....	-35 dBc.....	-32 dBc min
IM3 with 2 Tones @ 1 dbm	-50 dBc.....	-47 dBc min

Pass band Flatness

Any 24 MHz band	0.1 dB.....	0.2 dB
Input Return Loss	14 dB.....	11 dB
Output Return Loss	13 dB.....	11 dB
Noise Figure.....	6 dB.....	7 dB

Power Specifications

Voltage	12 to 20 VDC
Current	55 mA / channel

Mechanical Specifications LA141a & LA142a

Dimensions	4" x 3.5" x 7/8"
Weight	0.7 lb (0.3 kg)
Master Carton (44 units).....	11" x 9" x 9"
Master Carton Weight.....	21 lb. (9.5 kg)
Master Carton LA141a-T & LA142a-T (12 units).....	11" x 9" x 9"
Master Carton Weight.....	21 lb. (9.5 kg)

Mechanical Specifications LA144a

Dimensions	6" x 4.75" x 0.875"
Weight LA144a	1.5 lb (0.7 kg)
Weight LA144a-T	2 lb (0.9 kg)
Master Carton (12 units).....	11" x 9" x 9"
Master Carton Weight.....	18 lb. (8.2 kg)
Master Carton LA144a-T (12 units).....	11" x 9" x 9"
Master Carton Weight.....	26 lb. (11.8 kg)

Mechanical Specifications LA145a

Dimensions	7.5" x 4.875" x 0.875"
Weight LA145a	1.5 lb (0.7 kg)
Weight LA145a-T	2 lb (0.9 kg)
Master Carton (12 units).....	11" x 9" x 9"
Master Carton Weight.....	18 lb. (8.2 kg)
Master Carton LA145a-T (12 units).....	11" x 9" x 9"
Master Carton Weight.....	26 lb. (11.8 kg)

Environmental Specifications

Operating Environment:.....	Indoor/Outdoor
Ambient Temperature	-30° C to +70° C

Contents

SLIMLINE SEQ409 & LA144a OUTPUT 4

AU9 SL5 Dish to WB68 & WB616 8

WB68 & WB616 EXPANSION 9

AU9 SL5 to WB616 & SWM8 10

8 UNIT GARDEN STYLE MDU..... 11

HIGH RISE MDU TAP PER FLOOR 12

HIGH RISE MDU TAP PER (2) FLOORS 13

HIGH RISE MDU TAP PER (3) FLOORS 14

(3) FLOOR, TAP PER FLOOR..... 15

(3) FLOOR, (3) FLOOR IDF SPACING 16

(5) FLOOR, TAP PER (2) FLOORS..... 17

(5) FLOOR, TAP PER (3) FLOORS..... 18

Why does SONORA have DBS amplifiers with 14 dB gain, 28 dB gain and automatic gain?

When your only tool is a hammer, every problem looks like a nail. Each of the (3) DBS amplifier models has advantages for specific applications.

14 dB Gain Amplifiers

These amplifiers were developed to offset the specific amount of loss in an 8-way splitter or 150 feet of RG-6 coax. Our S5x8AMP is a zero loss hub using a model LA145a amplifier connected to (5) HRvS8 8-way splitters.

28 dB Gain Amplifiers

These amplifiers were developed to offset the specific amount of loss in an 8-way splitter AND 150 feet of RG-6 coax.

-20 dBm Automatic Gain Amplifiers

System design and installation is much simpler when the output level of the amplifier can be maintained over a range of input levels. The -20 dBm level was selected based on providing signal to (4) DBS switches without switch overload. (A 4-way has a typical loss of 10 dB so the net level is -30 dBm)

Amplifiers can be cascaded reliably when they are operated at an output level well below their maximum. The decision as to the operating level is controlled by the amplifier not the field technician.

SLIMLINE AMPLIFICATION

99° & 101° Odd (13V)

DIRECTV® model *SLIMLINE* dish with SL5 LNB signals were used to optimize the design of model LA144a 14 dB gain amplifier and SEQ409 equalizer. The frequency plots on the left show the 13V polarity of the dish after 100 feet of RG-6.

We start with the Ku signals at -38 dBm. The lower Ka signals at -34 dB.

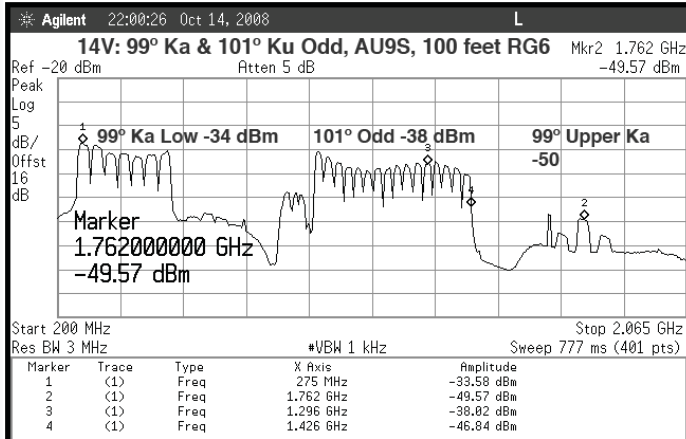

After SEQ409 equalization :

The Ku signals are -44 dBm. The Ka signals are at -45 dBm Ka.

We have a flat signal for amplification!

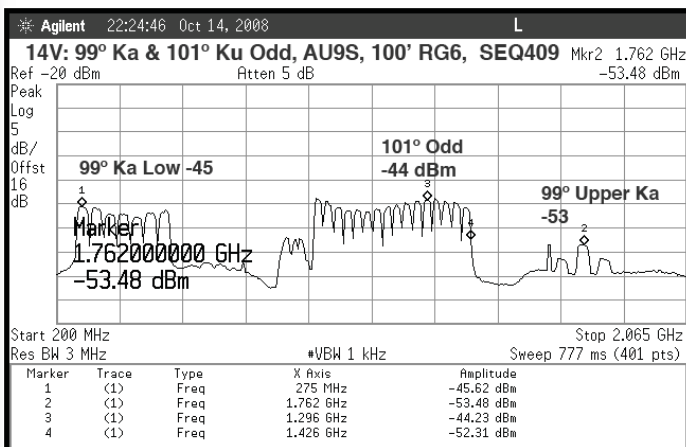

After SEQ409 equalization & LA144A amplification :

The Ku signals are -32 dBm. The Ka signals are at -36 dBm Ka.

We have a 4 dB pre-emphasized signal for distribution that in the Ku band is 6 dB stronger than received from the SL5!

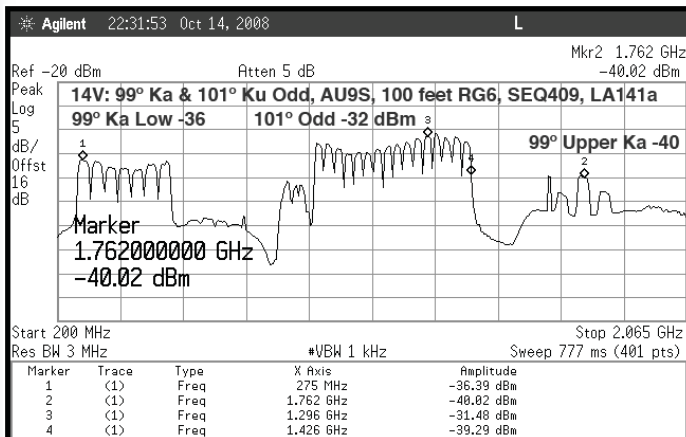

SLIMLINE AMPLIFICATION

99° & 101° Even (17V)

DIRECTV® model *SLIMLINE* dish with SL5 LNB signals were used to optimize the design of model LA144a 14 dB gain amplifier and SEQ409 equalizer. The frequency plots on the left show the 17V polarity of the dish after 100 feet of RG-6.

We start with the Ku signals at -39 dBm. The lower Ka signals at -36 dB.

After SEQ409 equalization :

The Ku signals are -45 dBm. The Ka signals are at -47 dBm Ka.

We have a flat signal for amplification!

After SEQ409 equalization & LA144A amplification :

The Ku signals are -31 dBm. The Ka signals are at -38 dBm Ka.

We have a 7 dB pre-emphasized signal for distribution that in the Ku band is 8 dB stronger than received from the SL5!

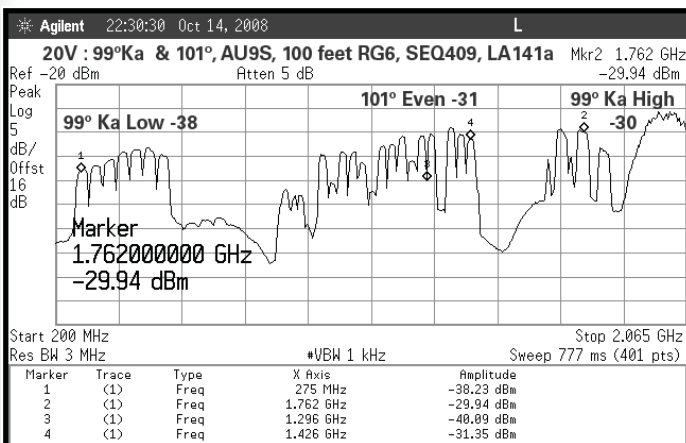
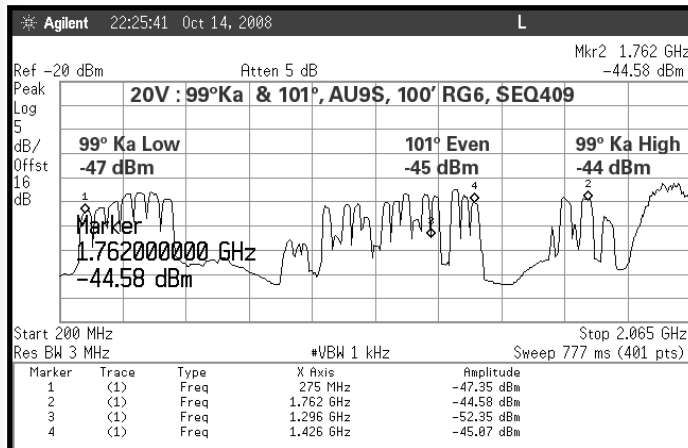
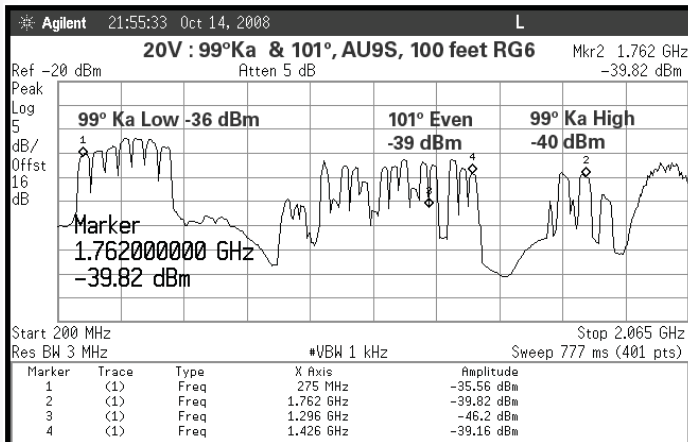

SLIMLINE AMPLIFICATION

103° & 119° Odd (13V & 22 kHz)

DIRECTV® model SLIMLINE dish with SL5 LNB signals were used to optimize the design of model LA144a 14 dB gain amplifier and SEQ409 equalizer. The frequency plots on the left show the 13V / 22 kHz polarity of the dish after 100 feet of RG-6.

We start with the Ku signals at -40 dBm.
The lower Ka signals at -32 dB.
This polarity has the highest Ka / Ku signal disparity

After SEQ409 equalization :
The Ku signals are -45 dBm.
The Ka signals are at -47 dBm Ka.

We have a flat signal for amplification!

After SEQ409 equalization & LA144A amplification :
The Ku signals are -31 dBm.
The Ka signals are at -38 dBm Ka.

We have a 7 dB pre-emphasized signal for distribution that in the Ku band is 8 dB stronger than received from the SL5!

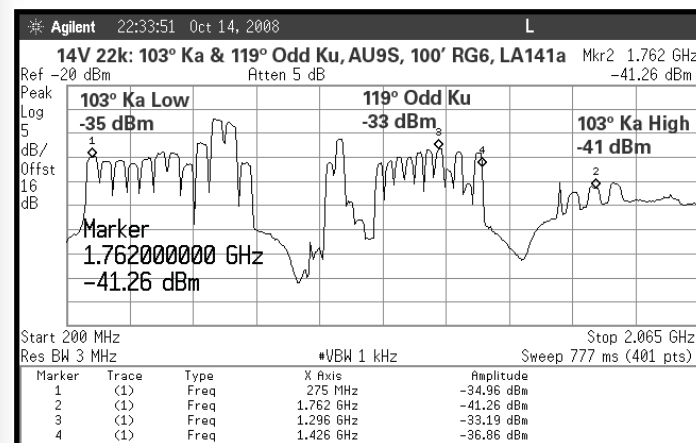
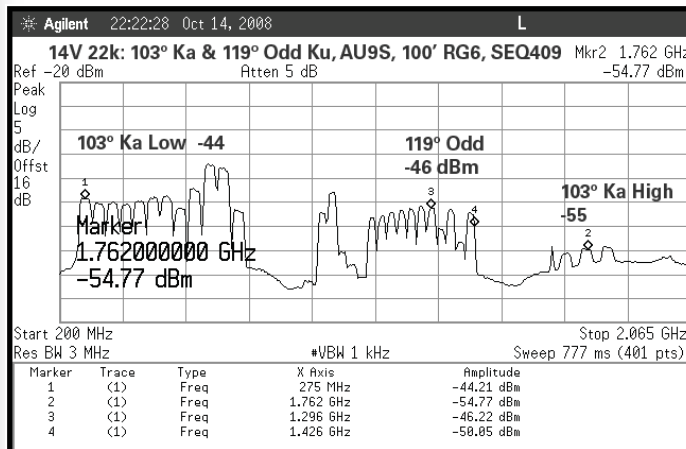
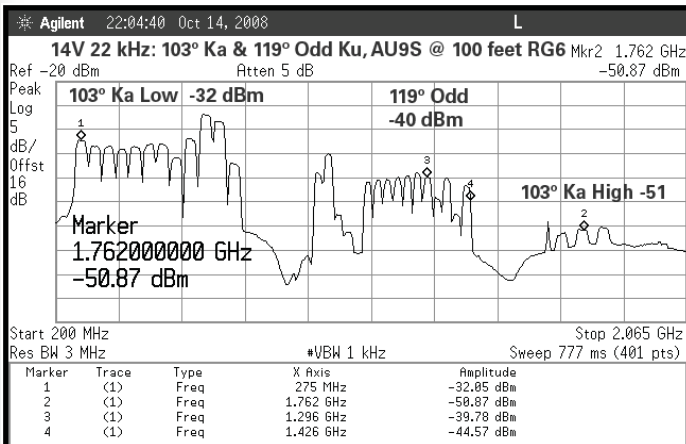

SLIMLINE AMPLIFICATION

103°, 110° & 119° Odd (17V & 22 kHz)

DIRECTV® model *SLIMLINE* dish with SL5 LNB signals were used to optimize the design of model LA144a 14 dB gain amplifier and SEQ409 equalizer. The frequency plots on the left show the 17V / 22 kHz polarity of the dish after 100 feet of RG-6.

We start with the 119° Ku signals at -41 dBm. The lower Ka signals at -36 dB.

After SEQ409 equalization :

The Ku signals are -47 dBm. The Ka signals are at -48 dBm Ka.

We have a flat signal for amplification!

After SEQ409 equalization & LA144A amplification :

The Ku signals are -34 dBm. The Ka signals are at -39 dBm Ka.

We have a 5 dB pre-emphasized signal for distribution that in the Ku band is 7 dB stronger than received from the SL5!

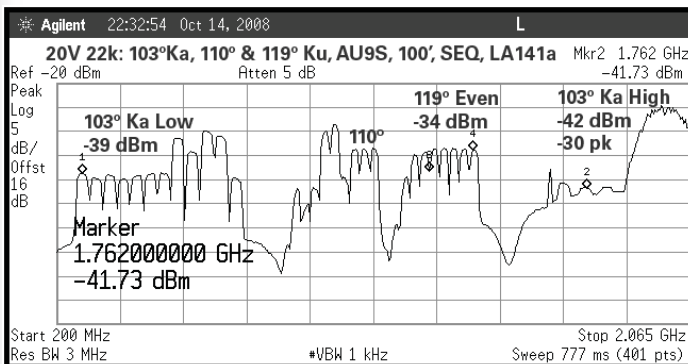
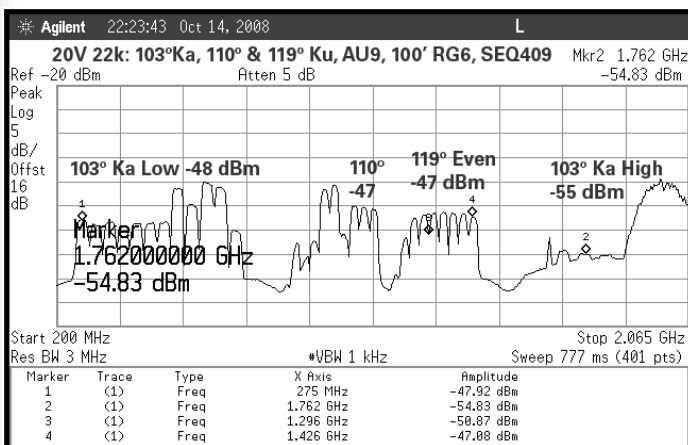
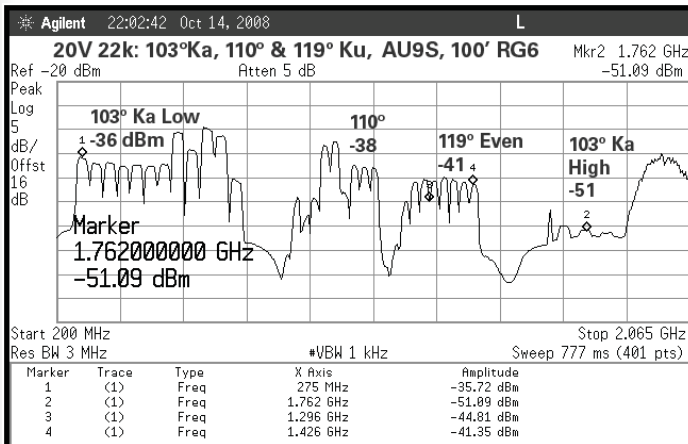

WB68 & Distant AU9 SL5

DIRECTV® recommends that the distance between receiver and dish be less than 100 feet of solid copper RG-6. At distances greater than 100 feet they recommend a DC voltage booster and a line amplifier.

Three issues are involved: LNB powering, control signal reception at the dish and signal level to the receiver.

Model HRPID1422A provides LNB powering and strong control signal to lock the dish. Without the locker, receivers power the WB68 which must power the LNB,

Model LA144a provides amplification of the DBS signals extending the range by 150 feet of RG6.

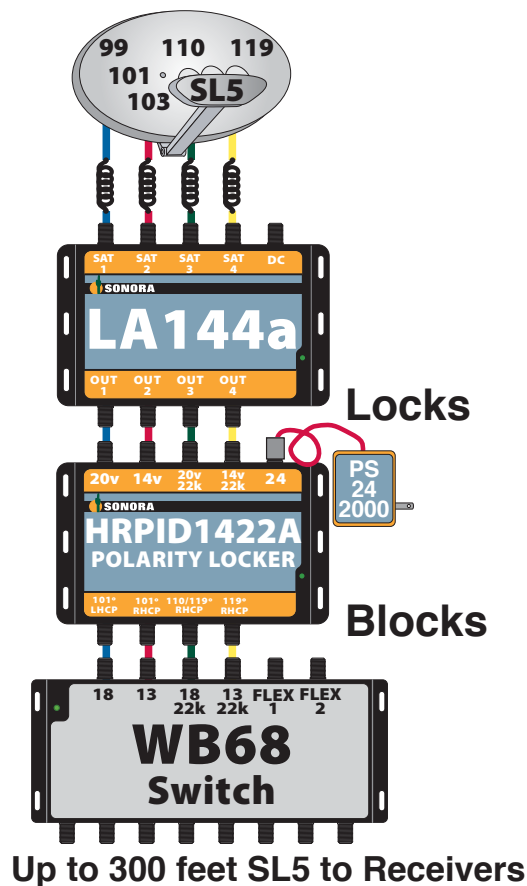

WB616 & Distant AU9 SL5

DIRECTV® model WB616 has an external power supply relieving the receiver from powering the dish.

While an improvement over the WB68, the LNB voltages generated by the HRPID1422A is two volts higher to better offset DC loss in the coax.

Model HRPID1422A also blocks control signals generated by the WB616 and substitutes a strong set of 22 kHz tones.

Power for the LA144a amplifier is provided by the HRPID1422A.

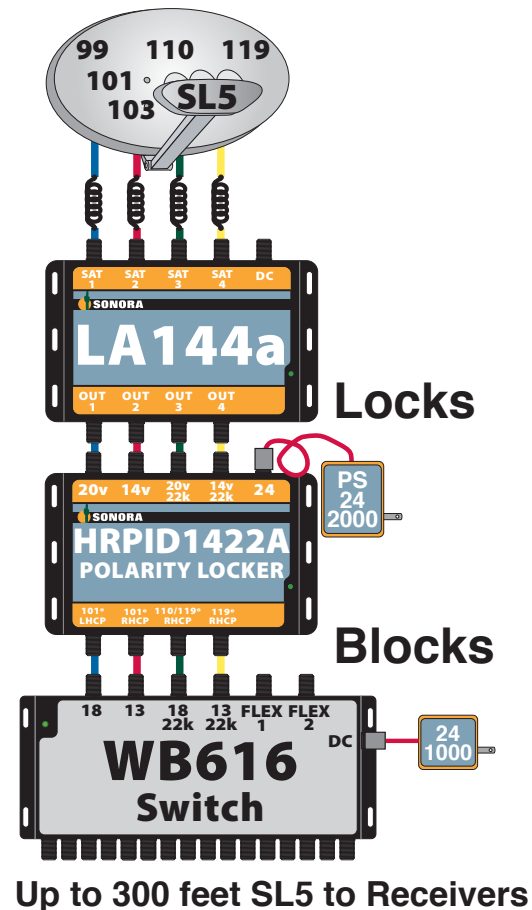

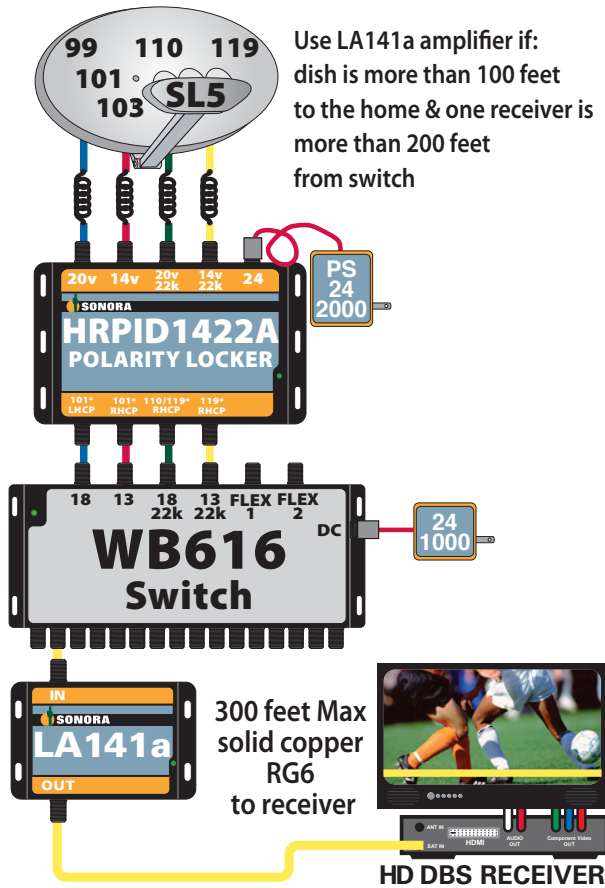

WB616 & (1) Distant Receiver

DIRECTV® recommends that the distance between receiver and dish be less than 100 feet of solid copper RG-6. At distances greater than 100 feet they recommend a DC voltage booster and a line amplifier.

A single LA141a amplifier may be used when just a single receiver exceeds the maximum distance.

Model HRPID1422A provides LNB powering and strong control signal to lock the dish. **Polarity locker outputs must match switch input voltages: 20V to 18V, 14V to 13V, 20V/22k to 18V/22k and 14V/22k to 13V 22k.**

Model LA141a provides amplification of the switched DBS signals extending the range by 150 feet of RG6.

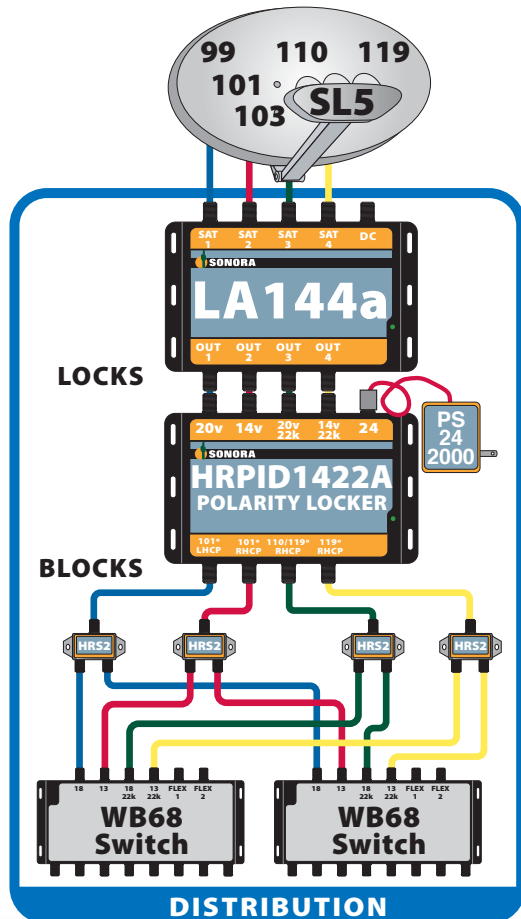

WB68 Expansion

DIRECTV® AU9 SL5 signals may be split to serve multiple model WB68 switches.

Four challenges must be overcome to achieve consistent performance; signal level, LNB powering LNB polarity locking and polarity to switch matching.

Splitting signals generates insertion loss that is offset by the LA144a amplifier. Use only DBS diode sterred or power passing one port splitters.

Model HRPID1422 blocks control signals generated by the (2) WB68 switches and substitutes a single strong set of 22 kHz tones.

Power for the LA144a amplifiers and SL5 LNB is provided by the HRPID1422A.

Colored jumpers allow polarity matching.

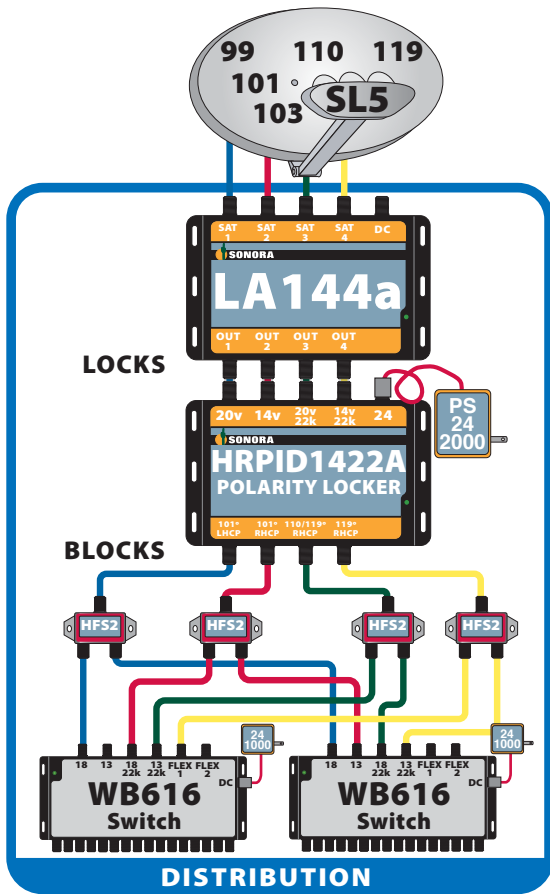

WB616 Expansion

DIRECTV® AU9 SL5 signals may be split to serve multiple model WB616 switches.

Four challenges must be overcome to achieve consistent performance; signal level, LNB powering LNB polarity locking and polarity to switch matching.

Splitting signals generates insertion loss that is offset by the LA144a amplifier. Use only DBS diode sterred or power passing one port splitters.

Model HRPID1422 blocks control signals generated by the (2) WB616 switches and substitutes a single strong set of 22 kHz tones.

Polarity locker outputs must match switch input voltages: 20V to 18V, 14V to 13V, 20V/22k to 18V/22k and 14V/22k to 13V 22k.

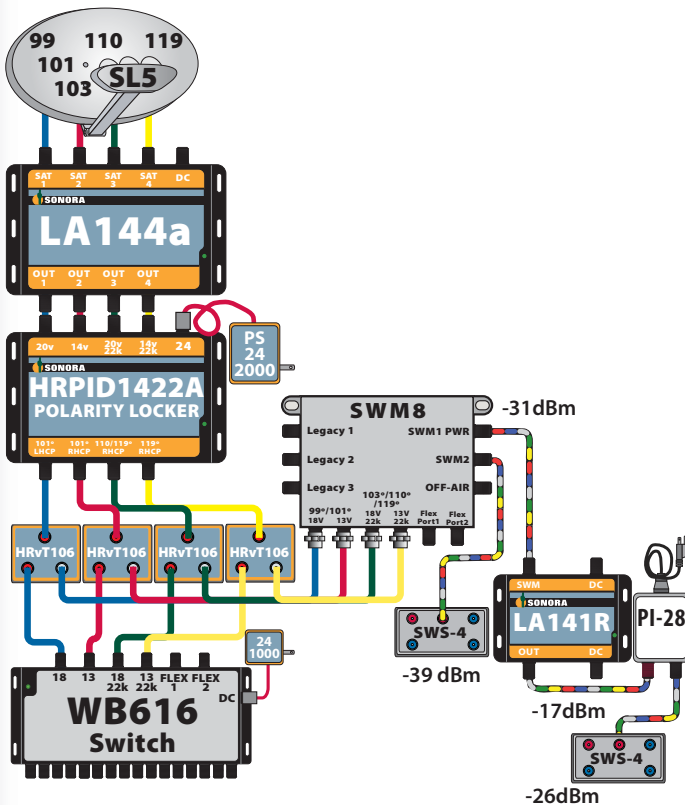

WB616 & (1) SWM8 Switch

A DIRECTV® WB616 switch presently serves multiple receivers. At a distant location served by a single coax, additional receivers are to be added.

Model HRPID1422A is used to polarity lock the AU9 dish. Model LA144a boosts each of the four polarities for splitting to the WB68 and SWM8 switch.

Model HRvT106 directional taps are used to split the signal to the switches. The low loss “thru” port of the tap goes to the WB616 switch.

The tap port with 6 dB insertion loss goes to the SWM8 switch. SWM8 switches have automatic gain to accept inputs from -55 to -25 dBm.

SWM8 switches have a -30 dBm output that is amplified with model LA141R to -17 dBm.

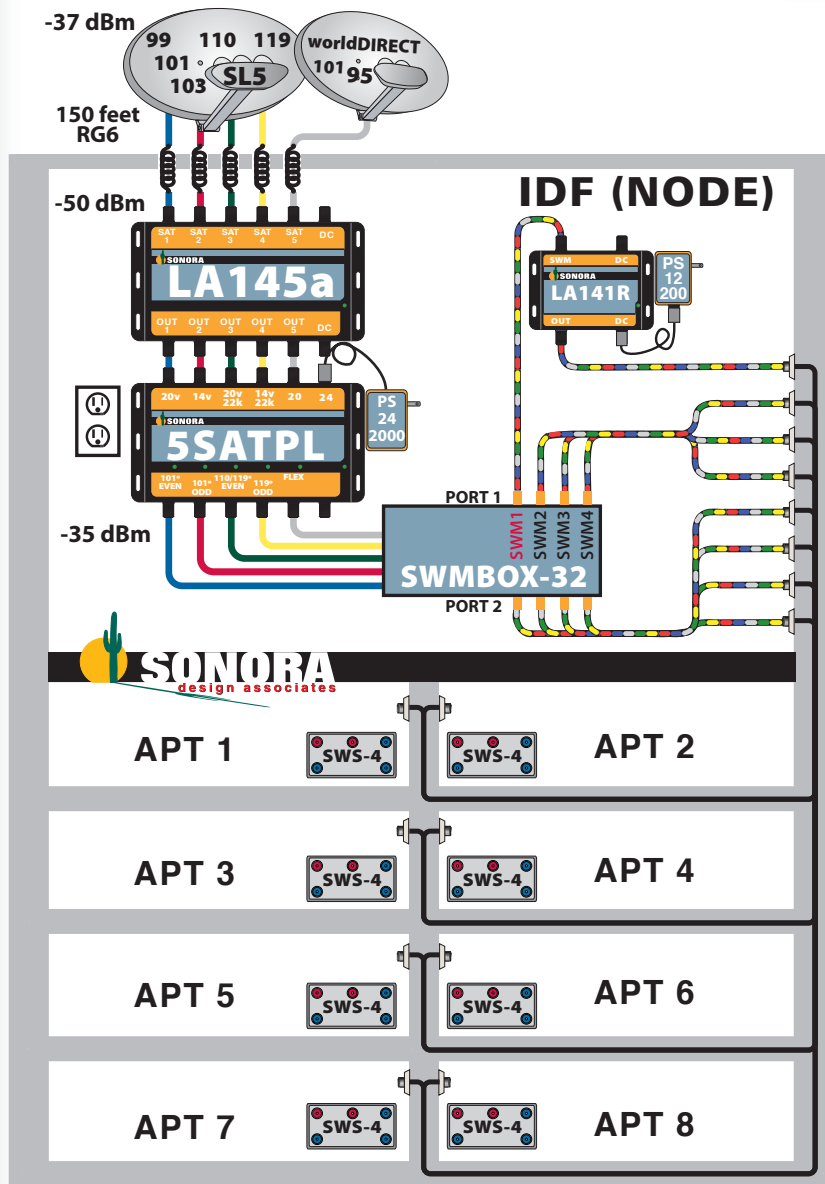

8U_Garden_100%

The system consists of distribution hubs that can be expanded when subscribers are added.

An AU9 SL5S signal consisting of the 99°,101°,103°, 110° and 119° is supplemented with a single dish focused on the 95° satellite.

Model LAL205a and 5SATPL start the distribution located up to 150 feet from the dishes.

An AU9 dish with WNR SL5 LNB typically has an output of -30 dBm.

The LA145a with 14 dB gain has an output of -31 dBm with the dish 150 feet from the amplifier.

Model SWMBOX-32 hubs provide the signals to up to (4) SWM8 switches provided a minimum of -42 dBm.

Model SWMBOX-64 hubs provide the signals to up to (8) SWM8 switches at zero loss.

LA141R SWM Extension

SWM8 switches have automatic gain controlled outputs of **-31 dBm**. (Note that the new Model SWM8Z switches have been reported to have outputs of **-37 dBm**) DIRECTV® receivers require -55 dBm of signal for full performance.

Model LAL141R extends the drop distance by 150 feet.

SWM8 switches have AGC simplifying the design. Inputs of **-25 dBm to -55 dBm** is required to each IDF.

Apartments requiring (4) tuners share a single SWM8 switch. Apartments requiring more than (4) tuners use a full SWM8.

Drop cables are tagged at the IDF to indicate the apartment number and the number of tuners in use.

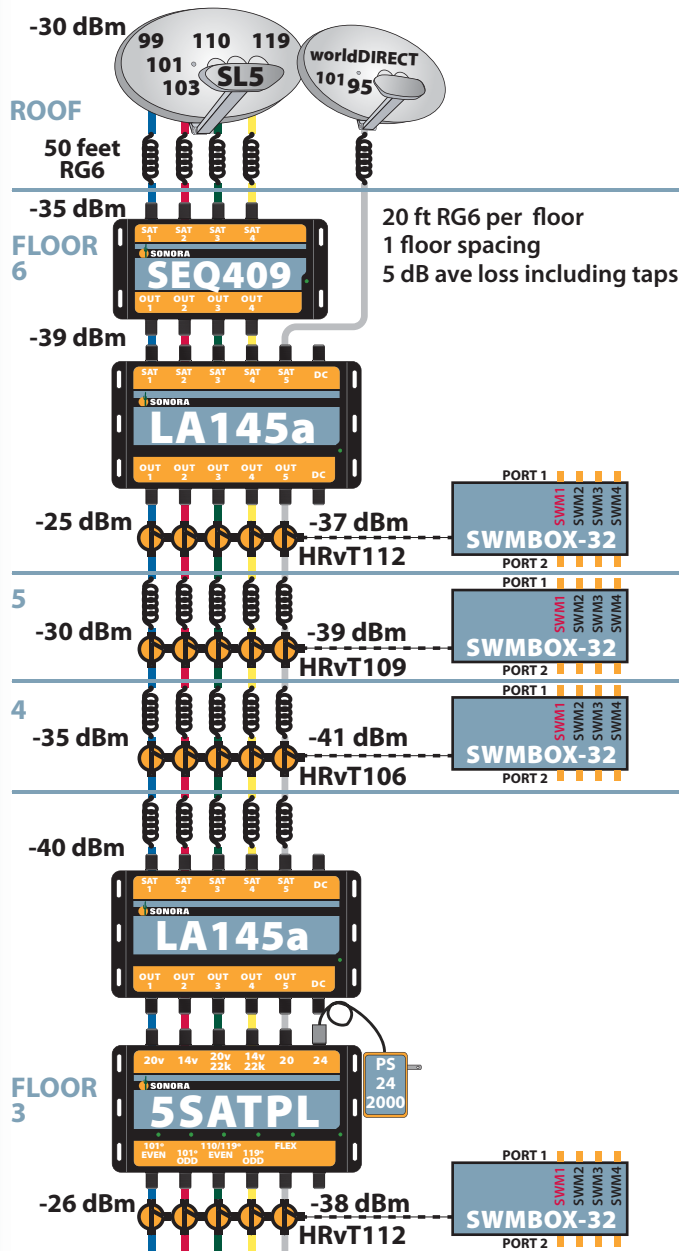

A single SWMBOX-32 allocates up to (4) SWM8 switches per floor to serve up to (8) apartments.

A single SWMBOX-64 allocates up to (8) SWM8 switches per floor to serve up to (16) apartments.

A SWMBOX-64 to SWMBOX-32 allocates up to (11) SWM8 switches per floor to serve up to (22) apartments.

A SWMBOX-64 to SWMBOX-64 allocates up to (15) SWM8 switches per floor to serve up to (30) apartments.

LA145a & HRvT Tap per floor

Model LA144a and LA145a are intended for high input expansion of DBS Ka/Ku signals. They can serve in small MDU applications to serve multiple distribution locations.

Model LA145a amplifier spacing is (3) floors when operated at -25 dBm output.

Model HRvT1xx directional couplers follow amplifiers to feed distribution hubs. The typical insertion loss is listed.

Tap output is the input level to the tap less the tap value (-25 dBm into a 12 dB tap = -37 dBm)

MHz/ dB	250	950	1450	2150
RG-6	3.1	6.4	7.9	9.7
HRvT112	1.6	1.7	1.9	2.3
HRvT109	1.8	1.9	2.2	2.7
HRvT106	2.3	2.5	2.9	3.5

SONORA measured 14 dB of insertion loss for the cascade of (3) taps and 60 feet of RG-6 coax to determine the 5 dB average loss per tap.

The measured loss at 250 MHz was 7 dB. The LA145a internal (4 dB) slope compensation offsets some of the 7 dB of slope.

Use model (1) SEQ409 per (2) LA145a amps for additional slope compensation.

Model SWMBOX-32 hubs provide the signals to up to (4) SWM8 switches with 9 dB loss. Inputs of -16 dBm to -41 dBm is required to each IDF.

Model SWMBOX-64 hubs hold up to (8) SWM8 switches at zero loss. SWM8 switches have automatic gain at inputs of -25 dBm to -50 dBm.

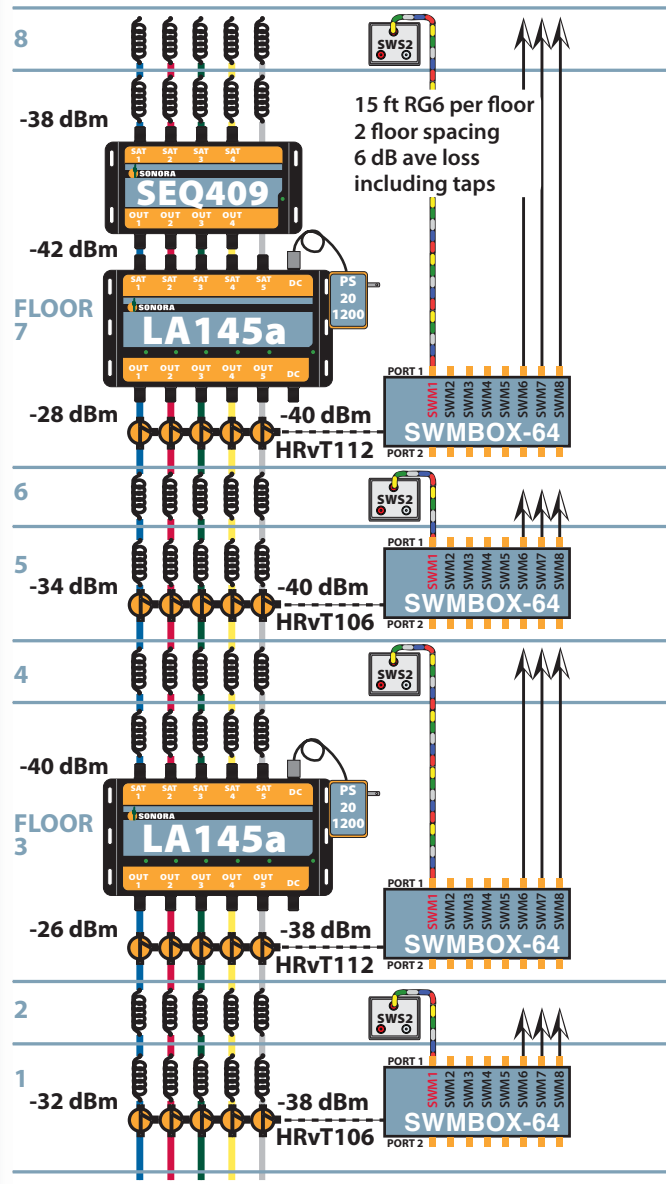

LA145a & HRvT Tap per (2) floors

Model LA145a 14 dB gain amplifier is followed with model HRvT1xx taps spaced on alternating floors connected via RG-6 coax. The configuration lowers Hub costs for low penetration buildings.

Model SWMBOX-32 hubs provide the signals to up to (4) SWM8 switches with 9 dB loss. Inputs of -16 dBm to -41 dBm is required to each IDF.

Model SWMBOX-64 hubs hold up to (8) SWM8 switches at zero loss. SWM8 switches have automatic gain at inputs of -25 dBm to -50 dBm.

Model HRvT1xx directional couplers follow amplifiers to feed distribution hubs. The typical insertion loss of taps and coax is listed.

Tap output is the input level to the tap less the tap value (-27 dBm into a 12 dB tap = -39 dBm)

MHz/ dB	250	950	1450	2150
RG-6	3.1	6.4	7.9	9.7
HRvT112	1.6	1.7	1.9	2.3
HRvT106	2.3	2.5	2.9	3.5

Model SWS-2 splitters are used on the alternating floors to split the SWM8 signal to feed (2) apartments.

A single SWMBOX-32 allocates up to (2) SWM8 switches per floor to serve up to (4) apartments per floor.

A single SWMBOX-64 allocates up to (4) SWM8 switches per floor to serve up to (8) apartments per floor.

A SWMBOX-64 to SWMBOX-32 configuration allocates (5) SWM8's to serve up to (10) apartments per floor.

A SWMBOX-64 to SWMBOX-64 configuration allocates up to (7) SWM8 switches per floor to serve up to (14) apartments per floor.

SONORA measured 12 dB of insertion loss at 2150 MHz of the cascade of (2) taps and 60 feet of RG-6. A loss of 6 dB average per tap is used .

The measured loss at 250 MHz was 6 dB. The LA145a internal (4 dB) slope compensation offsets some of the 6 dB of slope.

Use model (1) SEQ409 per (2) LA145a amps for additional slope compensation.

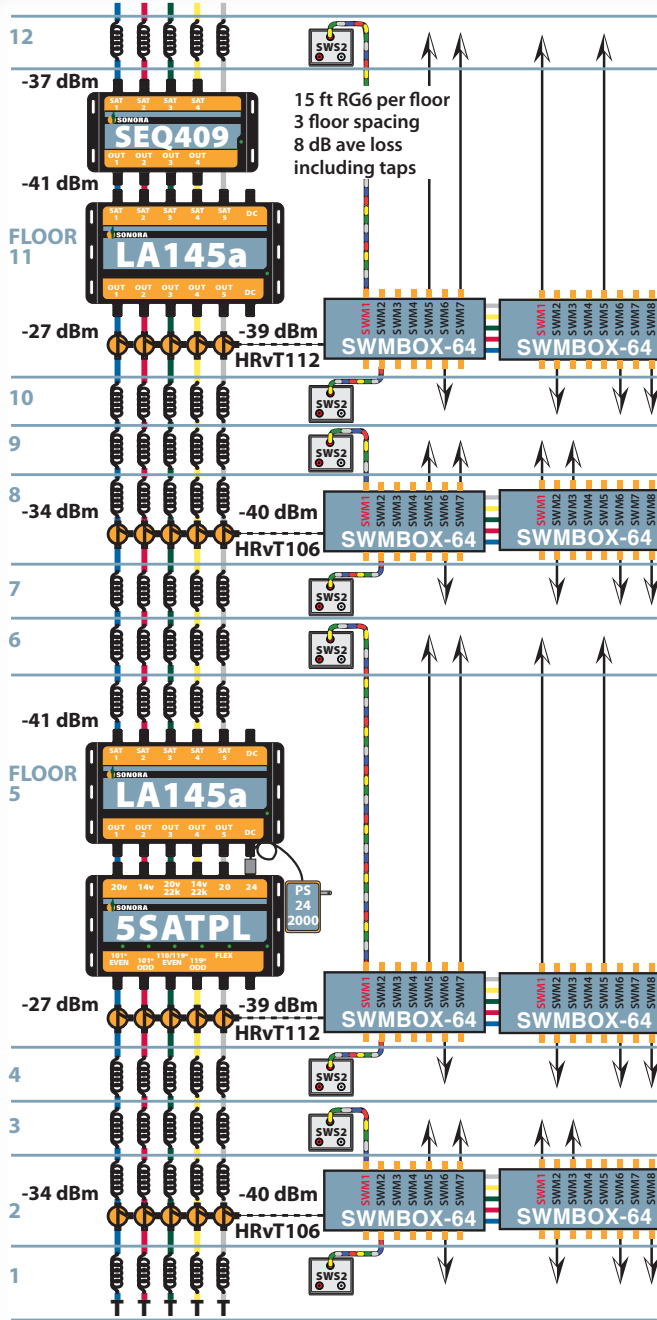

LA145a & Tap per (3) floors

Model LA145a 14 dB gain amplifier is followed with model HRvT1xx taps spaced on every third floor connected via RG-6 coax. This configuration lowers Hub costs for low penetration buildings.

Model LA145a amplifier with 14 dB gain controlled has a **spacing of (6) floors (16 dB)**.

Model HRvT1xx directional couplers follow amplifiers to feed distribution hubs. The typical insertion loss of taps and coax is listed.

Tap output is the input level to the tap less the tap value (-27 dBm into a 12 dB tap = -39 dBm)

MHz/ dB	250	950	1450	2150
RG-6	3.1	6.4	7.9	9.7
HRvT112	1.6	1.7	1.9	2.3
HRvT106	2.3	2.5	2.9	3.5

SONORA measured **15 dB** of insertion loss of the cascade of (2) taps and **90 feet of RG-6** coax to determine the **8 dB average loss per tap**.

The measured loss at **250 MHz** was **7 dB**. The LA145a internal (**4 dB**) slope compensation offsets some of the **8 dB** of slope.

The SWMBOX-64 to SWMBOX-64 cascade example allocates up to (5) SWM8 switches per floor to serve up to (10) apartments per floor.

Model SWS-2 splitters are used on the alternating floors to split the SWM8 signal to feed (2) apartments.

A SWMBOX-64 to the SWMBOX-32 configuration allocates up to (4) SWM8 switches per floor to serve up to (8) apartments per floor.

A single SWMBOX-64 allocates up to (3) SWM8 switches per floor to serve up to (5) apartments per floor.

Use model (1) SEQ409 per (2) LA145a amps for additional slope compensation.

Model SWMBOX-32 hubs provide the signals to up to (4) SWM8 switches with 9 dB loss. Inputs of -16 dBm to -41 dBm is required to each IDF.

Model SWMBOX-64 hubs hold up to (8) SWM8 switches at zero loss. SWM8 switches have automatic gain at inputs of -25 dBm to -50 dBm.

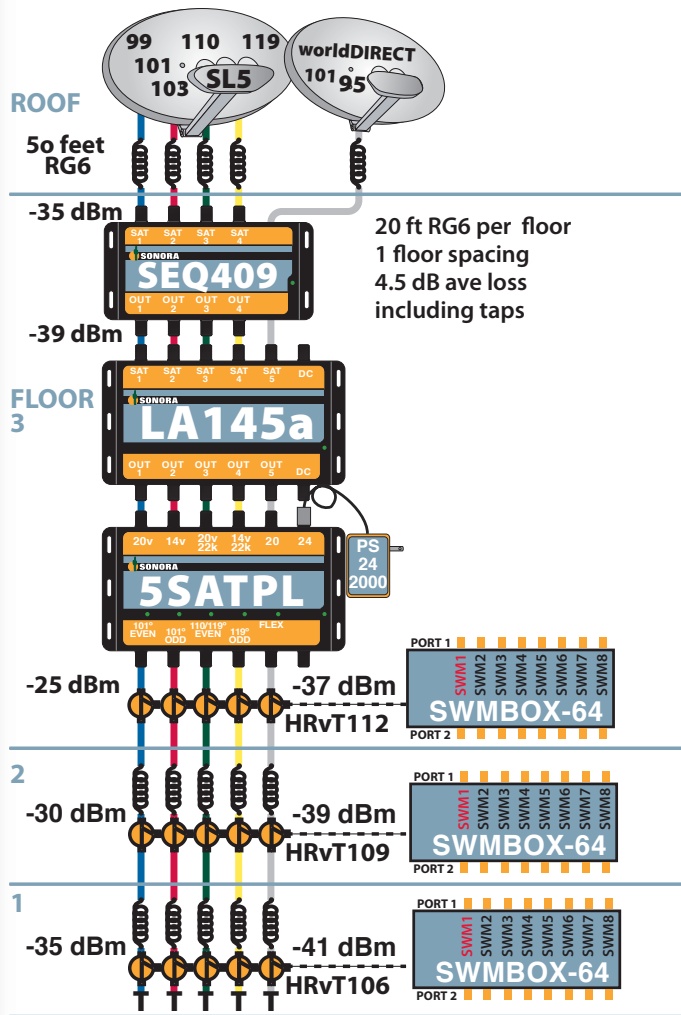

3FL_LA145A_1FS

An AU9 SL5S signal consisting of the 99°,101°,103°, 110° and 119° is supplemented with a WordDirect 95° signal.

Model SEQ409, LA145a and 5SATPL start the distribution located 50 feet from the dishes. An AU9 dish typically has an output of -30 dBm.

After 50 feet of RG-6 the signal to the SEQ409 equalizer is -35 dBm.

At the higher Ku frequency, the SEQ409 insertion loss is 4 dB. The LA145a with 14 dB of gain has an output of -25 dBm.

Model HRvTxx taps are used to couple some of the signal to the IDF equipment.

SONORA measured **14 dB** of insertion loss for the cascade of **(3) taps** and **60 feet** of RG-6 coax to determine the **4.5 dB average loss per tap**.

Model SWMBOX-32 hubs provide signals to up to (4) SWM8 switches with 9 dB loss. Inputs of -16 dBm to -41 dBm is required to each IDF.

Model SWMBOX-64 hubs hold up to (8) SWM8 switches at zero loss. SWM8 switches have automatic gain at inputs of -25 dBm to -50 dBm.

SWMBOX64 hubs can be cascaded to SWMBOX64 or SWMBOX32 hubs to expand penetration.

Bill of Materials 3FL_LA145A_1FS

- (1) SEQ409
- (1) LA145a
- (1) 5SATPL
- (5) HRvT112
- (5) HRvT109
- (5) HRvT106
- (3) SWMBOX-64

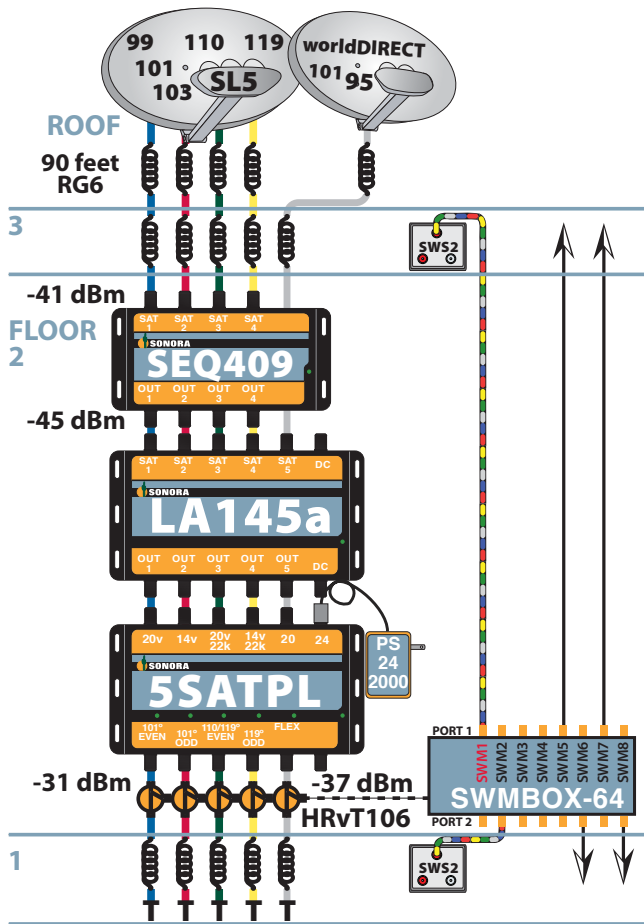

3FL_LA145A_3FS

Model SWMBOX-64 may be placed every third floor to minimize the distribution cost when penetration rates are low.

SWM8 outputs are sent up one floor and down one floor as needed to serve apartments. Model SWS-2 splitters are located on the upper and lower floors to split the SWM8 signal to (2) apartments.

Up to (3) SWM8 switches per floor could feed (6) apartments per floor (assuming (4) tuners per apartment).

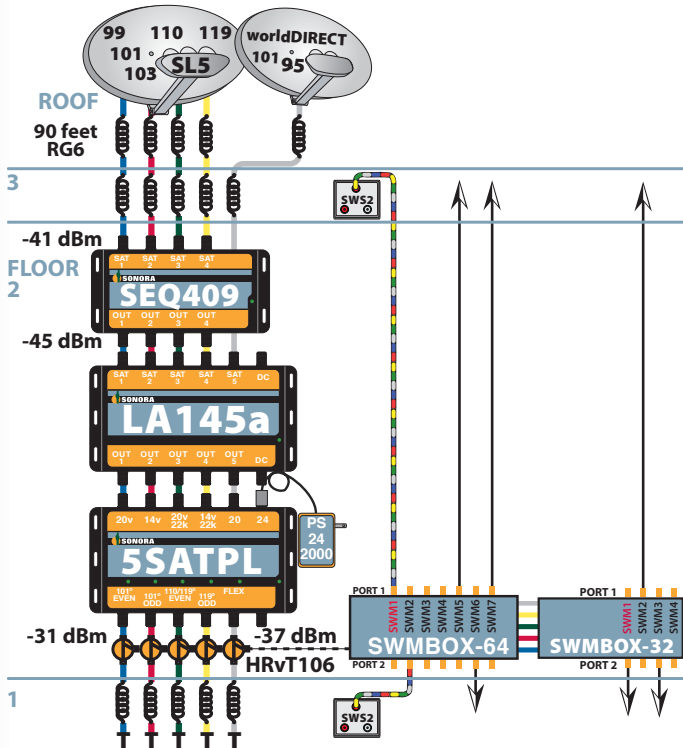

Cascading a SWMBOX-64 to a SWMBOX-32 would allow up to 4 switches per floor to feed 8 apartments.

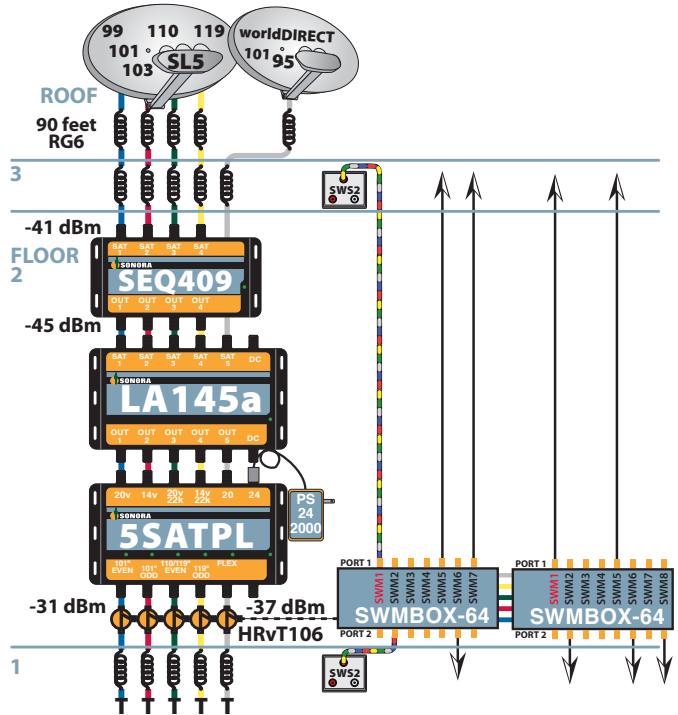

Cascading to a second SWMBOX-64 would allow up to 5 switches per floor to feed 10 apartments.

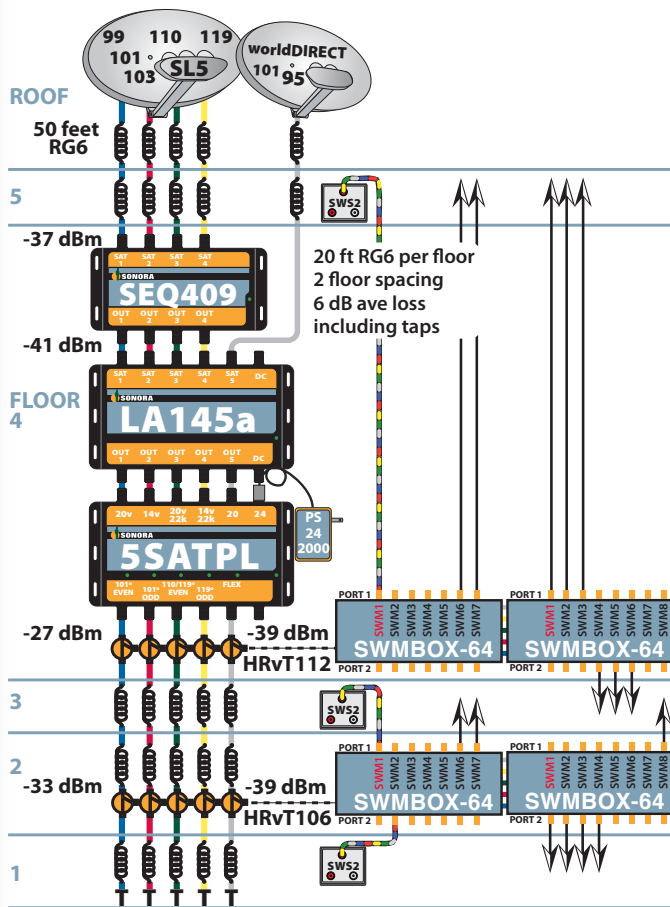

5FL_LA145A_2FS

This example has an IDF placed on alternate floors. Signals from SWMBOX-64 or SWMBOX-32 feed their floor plus or minus one floor.

SWM8 switches are added as subscribers are added. Up to (4) SWM8 switches may be allocated per floor with a single SWMBOX64. SWMBOX64 hubs may be cascaded for additional switches per floor.

Model SEQ409, LA145a and 5SATPL start the distribution located 50 feet from the dishes.

An AU9 dish typically has an output of -30 dBm. Signal passes through floor 5 so the total dish to floor 4 is 70 feet. After 70 feet of RG-6 the signal to the SEQ409 equalizer is -37 dBm.

At the higher Ku frequency, the SEQ409 insertion loss is 4 dB. The LA145a with 14 dB of gain has an output of -27 dBm.

Model HRvTxx taps are used to couple signal to the IDF equipment. SONORA measured 12 dB of insertion loss at 2150 MHz of the cascade of (2) taps and 60 feet of RG-6. A loss of 7 dB average per tap is used.

Bill of Materials: 5FL_LA145A_2FS

- (1) SEQ409
- (1) LA145a
- (1) 5SATPL
- (5) HRvT112
- (5) HRvT106

No change would be required to the backbone to expand the system with cascading SWMBOX's.

A SWMBOX64 feeding a SWMBOX32 would allow up to 5 switches per floor for 10 apartments.

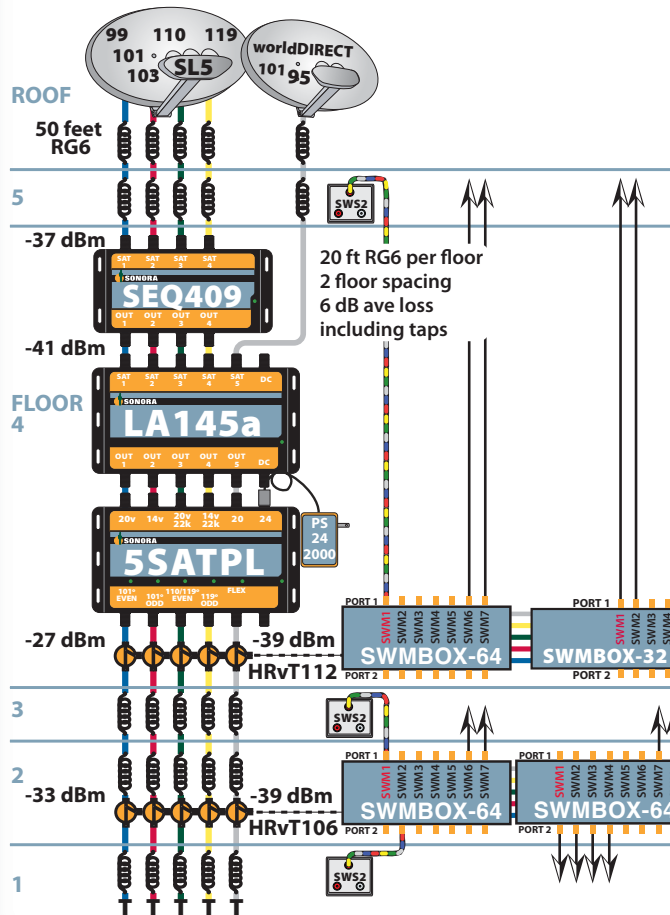

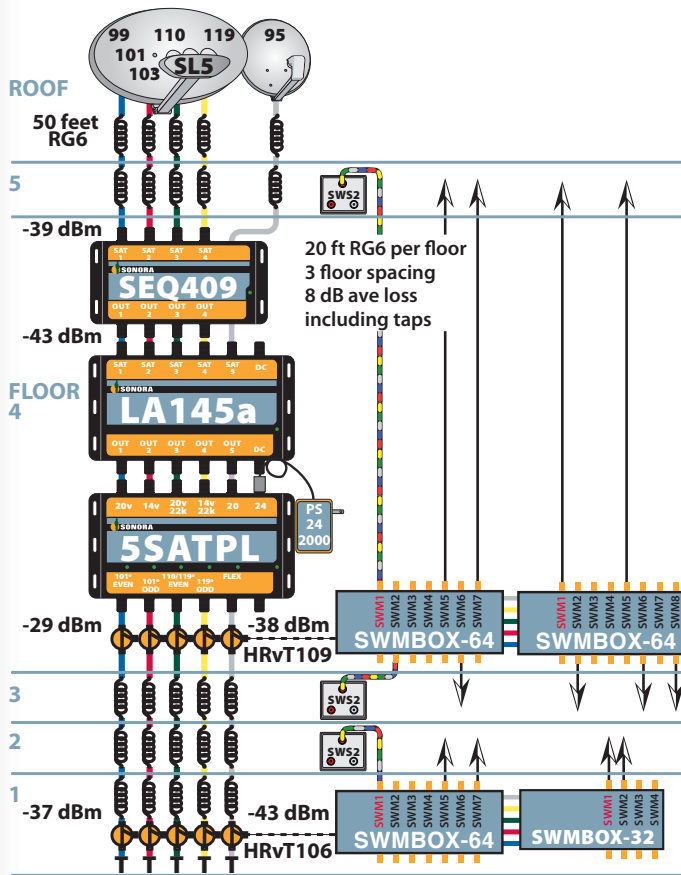

5FL_LA145A_3FS

Distribution hubs are placed on every third floor. Signals from SWMBOX-64 and SWMBOX-32 feed their floor plus or minus one floor.

Model HRvTxx taps are used to couple some of the signal to distribution hubs.

SONORA measured **8 dB** of insertion loss for the HRvT109 tap and **50 feet** of RG-6.

Model SWMBOX-64 hubs provide the signals to up to (8) SWM8 switches at zero loss.

Model SWMBOX-32 hubs provide the signals to up to (4) SWM8 switches with 9 dB loss. Inputs of -16 dBm to -41 dBm is required to each IDF.

The SWMBOX-64 to SWMBOX-64 cascade example allocates up to (5) SWM8 switches per floor to serve up to (10) apartments.

Model SWS-2 splitters are used on the alternating floors to split the SWM8 signal to feed (2) apartments.

Bill of Materials 5FL_LA145A_3FS

- (1) SEQ409 (5) HRvT09
- (1) LA145a (5) HRvT06
- (1) 5SATPL

The bottom example cascades a SWMBOX-32 to the SWMBOX-64. This configuration allocates up to (4) SWM8 switches per floor to serve up to (8) apartments.

A single SWMBOX-64 on alternating floors allocates up to (3) SWM8 switches per floor to serve up to (8) apartments.

A single SWMBOX-32 on alternating floors allocates up to (2) SWM8 switches per floor to serve up to (4) apartments.

